

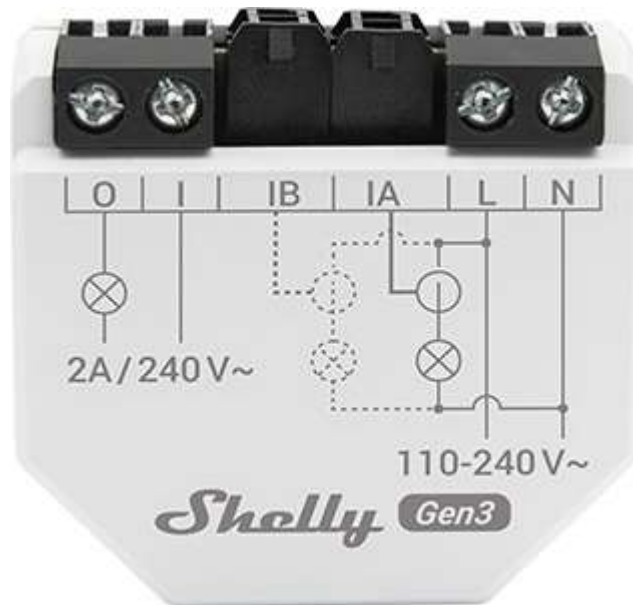

# Shelly EM Gen3 datasheet

## Shelly EM Gen3



### Device identification

- Device name: **Shelly EM Gen3**
- Device model: **S3EM-002CXCEU**
- Device SSID: **ShellyEMG3-XXXXXXXXXXXX**
- BLE Model ID: **0x1027**

### Short description

Shelly EM Gen3 (the Device) is a small form factor smart energy meter using up to 2 current transformers (contactless metering), which allows energy metering the consumption of electric appliances and reporting to a mobile phone, tablet, PC, or home automation system. It can work standalone in a local Wi-Fi network or it can also be operated through cloud home automation services. The Device has internal storage for data allowing for later retrieval. The Device has single dry contact switch for controlling external loads.

Shelly EM Gen3 can be accessed, controlled, and monitored remotely from any place where the User has internet connectivity, as long as the device is connected to a Wi-Fi access point and the Internet.

Shelly EM Gen3 can be retrofitted into standard electrical wall boxes, next to electrical appliances, power sockets, or in other places with limited installation space.

Shelly EM Gen3 has an embedded Web Interface which can be used to monitor, configure, and control the device.

### Main features

- Compact form factor
- Single phase, two channels measurement
- Current transformer connection
- Dry contact relay for contactor control



# Shelly EM Gen3 datasheet

- Real-time clock
- Data logs stored on device for up to 10 days of minute data records

## Use cases

- **Power Consumption Monitoring:** Monitor the power consumption of connected devices in real-time. This information can be valuable for understanding energy usage patterns and making informed decisions to reduce consumption.
- **Energy Efficiency Optimization:** Identify electrical energy consumption patterns and optimize electricity usage.
- **Appliance Health Check:** Keep track of the power usage of individual appliances to assess their health and performance over time. Sudden spikes or changes in power consumption may indicate issues with the appliance.
- **Cost Management:** With the knowledge of power consumption, you can estimate the cost of running specific devices and manage your electricity expenses more effectively.
- **Space-Efficient Retrofitting:** Integrate the device into standard electrical wall boxes, behind power sockets, light switches, or other locations with limited space.
- **Remote Monitoring:** Shelly EM Gen3 supports publishing data to Shelly cloud or other cloud based data collection and storage systems. This allows you to monitor power consumption even when you're away from home.
- **Local Monitoring:** Like the rest of the Shelly Wi-Fi line of devices Shelly EM Gen3 allows for local only monitoring and automations. Access stored energy consumption records directly from the device UI. Automate locally with rules based on instantaneous power consumption or energy consumer for a period of time.

## Main applications

- Residential
- MDU (Multi Dwelling Units - apartments, condominiums, hotels, etc.)
- Light commercial (small office buildings, small retail/restaurant/gas station, etc.)
- Government/municipal
- University/college
- Farming



# Shelly EM Gen3 datasheet

## Simplified internal schematics

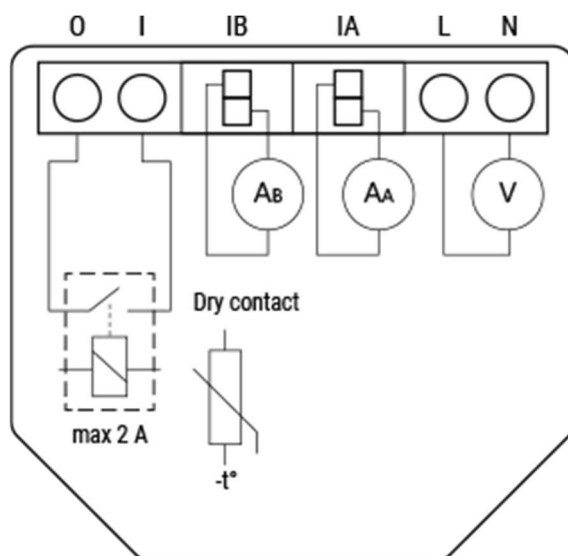

## Connectivity

- Wi-Fi
- Bluetooth

## Protocols

- MQTT
- HTTP
- WebSocket
- RPC

## Safety function

- Internal temperature sensing and reporting

## Supported load types

- Resistive (incandescent bulbs, heating devices)
- Capacitive (LED light drivers, capacitor banks, electronic equipment, motor start capacitors)
- Inductive (transformers, fans, refrigerators, air-conditioners)

## User interface

### Inputs

- One (Control) button
  - Press and hold for 5 seconds to enable Device access point and Bluetooth connection.
  - Press and hold for 10 seconds to factory reset the Device.

## Specifications

Quantity	Value
----------	-------



## Shelly EM Gen3 datasheet

<b>Physical</b>	
Size (HxWxD):	37x42x16 mm / 1.46x1.65x0.63 inch
Weight:	<ul style="list-style-type: none"><li>EM Gen3 - 23 g / 0.81 oz</li><li>CT 50A - 50 g / 1.76 oz</li></ul>
Screw terminals max torque:	0.4 Nm / 3.5 lbin
Conductor cross section:	0.5 to 4 mm <sup>2</sup> / 20 to 11 AWG (solid, stranded, and bootlace ferrules)
Conductor stripped length:	6 to 7 mm / 0.24 to 0.28 in
Mounting:	Wall console, Electrical cabinet
Shell material:	Plastic
Shell color:	<ul style="list-style-type: none"><li>White</li><li>Charcoal gray</li></ul>
Connectors color:	Black
<b>Environmental</b>	
Ambient working temperature:	-20 °C to 40 °C / -5 °F to 105 °F
Humidity:	30 % to 70 % RH
Max. altitude:	2000 m / 6562 ft
<b>Electrical</b>	
Power supply:	110 - 240 V~ 50/60 Hz
Power consumption:	< 1.2 W
External protection:	2 A, tripping characteristic B or C, 6 kA interrupting rating, Energy limiting class 3
<b>Output circuits ratings</b>	
Max. switching voltage:	240 V~
Max. switching current:	2 A/240 V~
<b>Sensors, meters</b>	
Voltmeter (AC):	110-240 V~ 50/60 Hz
Voltmeter accuracy:	±2%



## Shelly EM Gen3 datasheet

Ammeter (AC):	0 - 80A
Ammeter accuracy:	$\pm 2\%$ (2 - 50 A), $\pm 2\%$ (1 - 2 A), $\pm 5\%$ (0 - 1 A)
Compatible current transformers:	<ul style="list-style-type: none"><li>• CT 50A (included in the package)</li><li>• CT 80A</li></ul>
Power and energy meters:	<ul style="list-style-type: none"><li>• Active and apparent power</li><li>• Active and apparent energy</li><li>• Power factor</li><li>• Fundamental active and fundamental reactive energy</li></ul>
Channel-to-channel calibration minimum load:	500 W
No load threshold:	30 VA per channel
Measurement data storage:	At least 10 days of 1 min data resolution
Data export:	<ul style="list-style-type: none"><li>• CSV for PQ recorded values</li><li>• JSON format export through RPC</li></ul>
Internal-temperature sensor:	Yes
<b>Radio</b>	
<b>Wi-Fi</b>	
Protocol:	802.11 b/g/n
RF band:	2412 - 2472 MHz
Max. RF power:	< 20 dBm
Range:	Up to 30 m / 100 ft indoors and 50 m / 160 ft outdoors (Depends on local conditions)
<b>Bluetooth</b>	
Protocol:	4.2
RF band:	2402 - 2480 MHz
Max. RF power:	< 4 dBm
Range:	Up to 10 m / 33 ft indoors and 30 m / 100 ft outdoors (Depends on local conditions)



## Shelly EM Gen3 datasheet

<b>Microcontroller unit</b>	
CPU:	ESP-Shelly-C38F
Flash:	8 MB
<b>Firmware capabilities</b>	
Schedules:	Yes
Webhooks (URL actions):	20 with 5 URLs per hook
Scripting:	Yes
MQTT:	Yes
Encryption:	Yes (Transport level)
Authentication:	Yes (Application and transport level)

## Shelly EM Gen3 datasheet

### Basic wiring diagrams

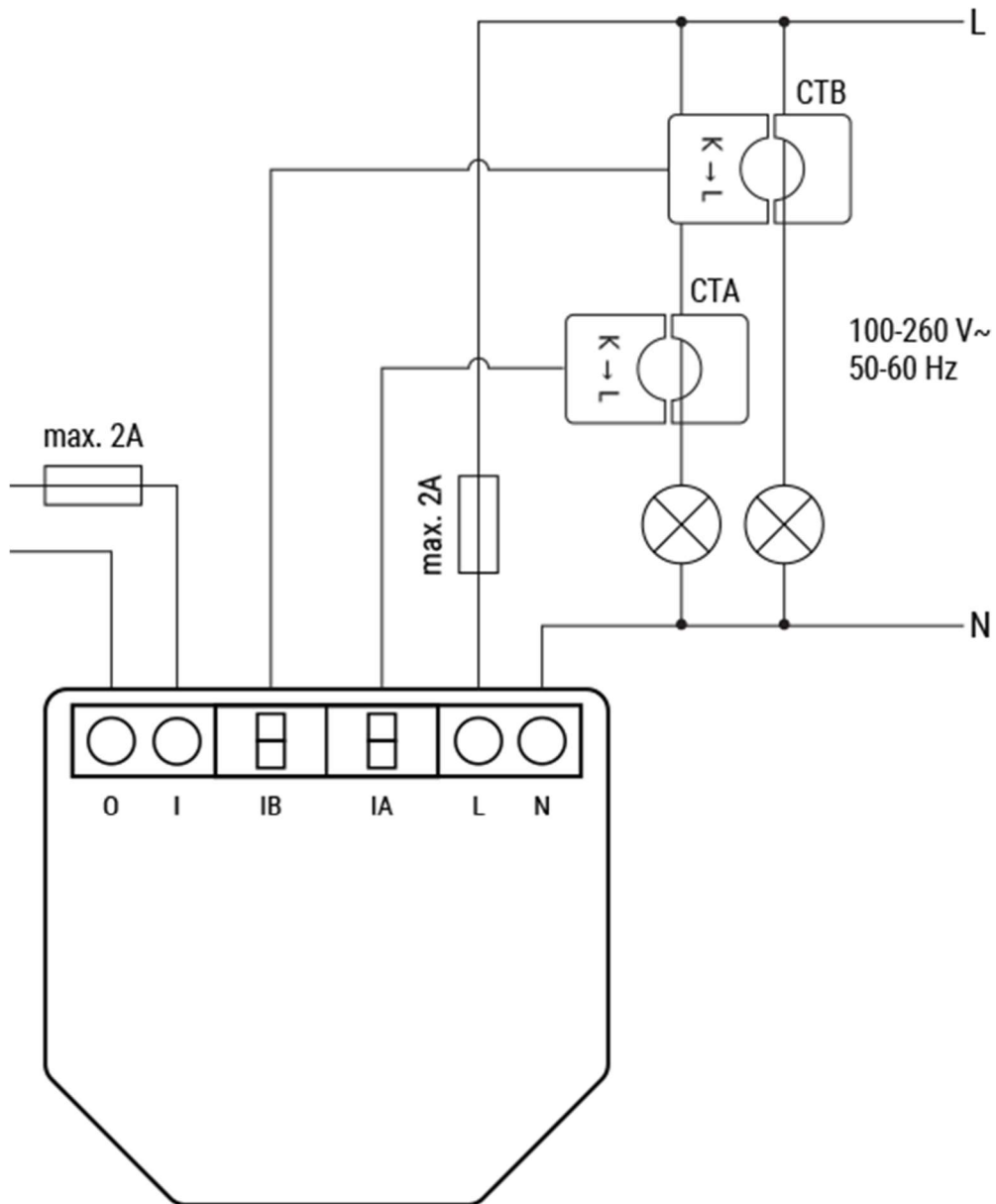

### Legend

Terminals		Wires	
<b>O</b>	Load circuit output terminal	<b>L</b>	Live (100-260 V~) wire
<b>I</b>	Load circuit input terminal	<b>N</b>	Neutral wire
<b>IA</b>	First channel current transformer input	<b>Current transformers</b>	



# Shelly EM Gen3 datasheet

<b>IB</b>	Second channel current transformer input	<b>CTA</b>	First channel current transformer
<b>L</b>	Live (100-260 V~) terminal	<b>CTB</b>	Second channel current transformer
<b>N</b>	Neutral terminal		

## Shelly Smart Control

- [Adding the device to the Shelly Smart Control](#)

## Troubleshooting

1. **Check the correct installation of the CT:**
  - If negative readings on a measured circuit are read and are not expected, check the correct installation of the CT (K->L).
2. **Ensure that the device is properly powered:**
  - Check power cables, outlets, and any power indicators on the device.
3. **Inspect Connections:**
  - Verify that all connections, including cables and wiring, are secure and properly seated. Loose connections can lead to functionality issues.
4. **Review Device Settings:**
  - If applicable, check and review the device settings. Ensure that configurations are correct and match your intended use.
5. **Update Firmware/Software:**
  - Check if there are any available firmware or software updates for the device. Keeping the device up-to-date can resolve known issues and improve performance.
6. **Restart or Reboot:**
  - Sometimes, a simple restart can resolve temporary glitches. Turn off the device, wait a few seconds, and then power it back on.
7. **Check Network Connection:**
  - If the device is connected to a network, ensure that the network settings are correct. Test the network connection and consider restarting routers or switches if needed.
8. **Inspect Physical Components:**
  - Physically inspect the device for any signs of damage, overheating, or unusual behavior.
9. **Check Compatibility:**
  - Ensure that the device is compatible with other components in your system, including hardware and software. Incompatibility issues can lead to malfunctions.
10. **Monitor Environmental Factors:**
  - Consider environmental factors such as temperature and humidity.
11. **Inspect Power Supply Quality:**
  - Poor power quality, including voltage spikes or fluctuations, can affect device performance. Consider using a surge protector or voltage regulator if needed.

\*These are general troubleshooting steps, and the specific steps may vary based on the type of device or issue you are facing. If the issue persists and you are unable to resolve it, consider reaching out to our [technical customer support](#).

## Components and APIs

- [This device](#)



# Shelly EM Gen3 datasheet

- [All Shelly devices and services](#)

## Compliance

- [Shelly EM Gen3 multilingual EU declaration of conformity 2025-07-22.pdf](#)
- [Shelly EM Gen3 UK PSTI ACT Statement of compliance.pdf](#)

## Printed user guide

- [Shelly EM Gen3 multilingual printed user and safety guide.pdf](#)