



# Shelly Pro 3EM-3CT63 datasheet

## Shelly Pro 3EM-3CT63





# Shelly Pro 3EM-3CT63 datasheet



## Device identification

- Device name: **Shelly Pro 3EM 3CT63**
- Device model: **SPEM-003CEBEU63**
- Device SSID: **ShellyPro3EM3CT63-XXXXXXXX**
- Device Bluetooth ID: **0x1025**

## Short description

Shelly Pro 3EM-3CT63 (the Device) is a DIN rail mountable single or three-phase energy meter. Enhanced with all the gen2 firmware flexibility and LAN connectivity, it provides professional integrators with additional options for end-customer solutions. It can work standalone in a local LAN and/or Wi-Fi network, or it can also be operated through cloud home automation services through Modbus, MQTT, HTTP, and WebSocket. All inbound connections support TLS.

The Device reports accumulated energy as well as instantaneous voltage, current, active, and apparent power per phase/channel in real time. It stores data in non-volatile memory that can be retrieved for a period of up to 60 days in 1-minute intervals.

The Device has a real-time clock to keep the correct time if the connection to an SNTP server is lost.

Shelly Pro 3EM-3CT63 can be accessed, set up, and monitored remotely by the User, as well as the Device can access and communicate with an automation system, as long as they are in the same network infrastructure.

The Device has an embedded Web Interface which can be used to monitor and control the device, as well as adjust its settings.

**⚠NOTICE!** The Device does not have a built-in relay. Contactor control is provided using a [Shelly Pro 3EM Switch Add-on](#) attached to the Shelly Pro 3EM-3CT63.

## Main features

- 4 Quadrant measurement
- DIN rail mounting
- Multiple connection types: three phase or single phase installations
- Current transformer connection: non contact measurements.
- Phase sequence error detection<sup>1</sup> (option)



# Shelly Pro 3EM-3CT63 datasheet

- Channel-to-channel calibration<sup>2</sup>
- No load threshold<sup>3</sup>
- Optical pulse indication of energy usage
- Real-time clock: stored data keeps correct timestamps even if the internet connection is interrupted.<sup>4</sup>
- Data logs: up to 60 days of data stored on the device for later retrieval
- External contactor control: loads can be controlled based on device automation or scripts. Available with the addition of the Shelly 3EM Switch Add-on
- Accuracy Class B (active energy)<sup>5</sup>
- Photovoltaic ready

<sup>1</sup> The Device has phase sequence error detection circuits. This detection works on phase voltages and considers only the zero crossings. The regular succession of these zero-crossing events is Phase A followed by Phase B followed by Phase C. If the sequence of zero-crossing events is, instead, Phase A followed by Phase C followed by Phase B, then a phase\_sequence error is reported when the Phase sequence error detection option is enabled.

<sup>2</sup> At least 500 W load is required for each channel.

<sup>3</sup> In case the total load for the three channels drops below 30 VA per channel the measured power level will be displayed, but no consumed energy will be accumulated to the energy statistics and a No load threshold notification will be displayed in the Device web interface and the mobile application.

<sup>4</sup> Shelly devices rely on internet connection for device clock. In case of installation network requirement or service interruption, the built-in clock provides correct timestamps for records.

<sup>5</sup> The Device has a measurement accuracy of 1%, based on internal design validation and testing.

## Use cases

Combined 3-phase current transformer (CT) that is designed to be mounted directly over a circuit breaker

- **Industrial Power Distribution:**
  - In industrial settings with complex power distribution systems, a combined 3-phase CT mounted over a circuit breaker can efficiently measure and monitor current levels. This is crucial for optimizing energy usage and identifying potential issues in real-time.
- **Commercial Buildings and Facilities:**
  - For commercial buildings and facilities, where space is often limited in electrical panels, the compact design of the CT is beneficial. Mounting it directly over circuit breakers allows for efficient use of space while ensuring accurate current measurement.
- **Motor Control Centers (MCCs):**
  - Motor control centers, which are commonly found in manufacturing plants and industrial facilities, often have multiple circuit breakers. A combined 3-phase CT mounted over each breaker provides an integrated solution for monitoring motor currents, aiding in preventive maintenance and troubleshooting.
- **Data Centers:**
  - In data centers, where precise monitoring of power consumption is crucial, combined 3-phase CTs can be installed over circuit breakers to measure the current flowing through critical equipment.
- **Renewable Energy Installations:**



# Shelly Pro 3EM-3CT63 datasheet

- Combined 3-phase CTs can be used in renewable energy installations, such as solar or wind power systems. By mounting them directly over circuit breakers in the control panels, accurate current measurements can be obtained for monitoring and control purposes.
- **Substation Monitoring:**
  - In electrical substations, where space is often at a premium, combined 3-phase CTs can be advantageous. Installing them directly over circuit breakers helps in monitoring the current levels in the different phases, contributing to the overall stability and reliability of the substation.
- **Building Management Systems (BMS):**
  - For intelligent building management systems, having accurate real-time data on current consumption is essential. Combined 3-phase CTs can be installed over circuit breakers to provide the necessary information for energy management and demand response strategies.
- **Power Quality Monitoring:**
  - In applications where maintaining power quality is critical, such as in sensitive electronic equipment or medical facilities, combined 3-phase CTs can be used to monitor current waveforms and identify any anomalies that might affect the quality of power supplied.
- **Electrical Panel Upgrades:**
  - During electrical panel upgrades or retrofits, space constraints may arise. A combined 3-phase CT, designed for direct mounting over circuit breakers, offers a space-saving solution without compromising accurate current measurement.
- **Smart Grid Deployments:**
  - In the context of smart grids, where real-time data is essential for grid management and optimization, combined 3-phase CTs can be deployed over circuit breakers to provide accurate current information for monitoring and control purposes.

In each of these use cases, the combined 3-phase CT offers a space-efficient and integrated solution for current measurement, contributing to the overall efficiency, safety, and reliability of the electrical systems.

## Shelly Pro 3EM-3CT63 datasheet

### Simplified internal schematics

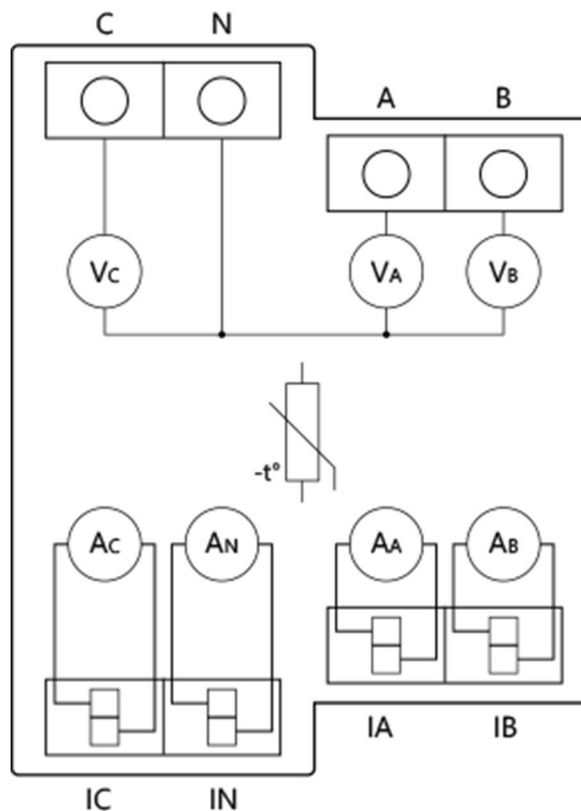

### Device electrical interfaces

#### Inputs

- 4 line inputs on screw terminals: 3 L and 1 N
- 4 current transformer inputs: 3 for L current measurements and 1 for N current measurement

#### Ethernet port

- 1 RJ45 connector

**⚠CAUTION!** Plug in or unplug the LAN cable only when the Device is powered off! The LAN cable connector must not be metallic in the parts touched by the user to plug in or unplug the cable.

#### Add-on interface

- Shelly proprietary serial interface



# Shelly Pro 3EM-3CT63 datasheet

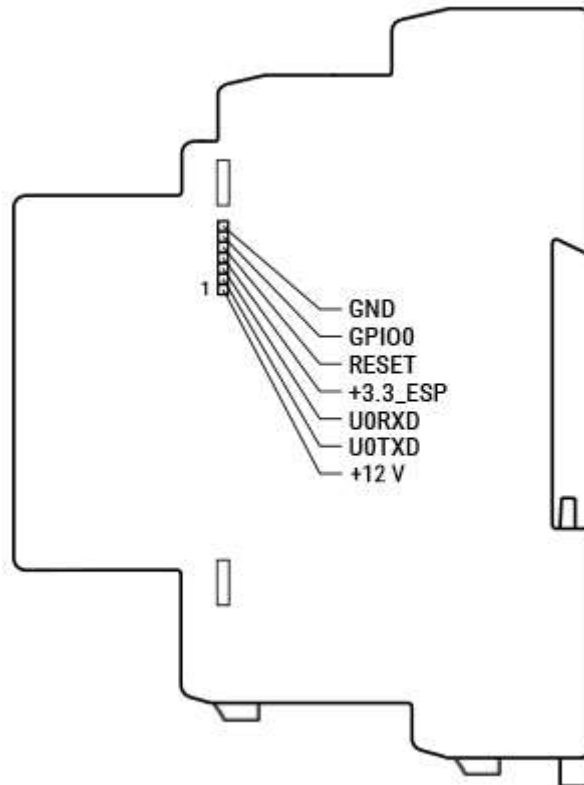

**⚠CAUTION!** High voltage on the add-on interface when the Device is powered!

## Detailed inputs and outputs description

Connector to Shelly Pro 3EM-3CT63

- three 2-pin MX3.0-2x1Y connectors

### Inputs

- 6 current transformer line inputs on screw terminals: 3 for + current measurements and 3 for - current measurement

### Connectivity

- Ethernet
- Wi-Fi
- Bluetooth

### Protocols

- Modbus
- MQTT
- RPC

### Safety function

- Internal temperature sensing and reporting



# Shelly Pro 3EM-3CT63 datasheet

## Supported load types

- Resistive (incandescent bulbs, heating devices)
- Capacitive (LED light drivers, capacitor banks, electronic equipment, motor start capacitors)
- Inductive (transformers, fans, refrigerators, air-conditioners)

## User interface

### Inputs

- One tactile dome button
  - Press briefly to toggle the state of the relay in the attached Shelly Pro 3EM Switch Add-on.
  - Press and hold for 5 sec to activate Device AP.
  - Press and hold for 10 sec to factory reset.

### Outputs

- LED indication
  - Power: Red light if the power supply is connected.
  - Wi-Fi (varies):
    - Blue light if in AP mode.
    - Red light if in STA mode, and not connected to a Wi-Fi network.
    - Yellow light if in STA mode, and connected to a Wi-Fi network. Not connected to Shelly Cloud or Shelly Cloud disabled.
    - Green light if in STA mode, and connected to a Wi-Fi network and the Shelly Cloud.
    - The LED will be flashing Red/Blue if OTA update is in progress.
  - LAN: Green light if LAN is connected.
  - Count: Red light will be flashing when the Device is measuring energy according to settings with frequency dependent on the energy flowing through the measured circuit.

## Specifications

Quantity	Value
<b>Physical</b>	
Size (HxWxD):	<ul style="list-style-type: none"><li>• Shelly Pro 3EM-3CT63: 94x19x69 mm / 3.70x0.75x2.71 in</li><li>• Shelly 3CT63: 14x54x26 mm / 0.55x2.12x1.02 in</li></ul>
Weight:	<ul style="list-style-type: none"><li>• Shelly Pro 3EM-3CT63: 62 g / 2.19 oz</li><li>• Shelly 3CT63: 32 g / 1.12 oz</li></ul>
Screw terminals max torque:	0.4 Nm / 3.5 lbin
Conductor cross section:	<ul style="list-style-type: none"><li>• Shelly Pro 3EM-3CT63: 0.5 to 2.5 mm<sup>2</sup> / 20 to 14 AWG</li><li>• Shelly 3CT63: 0.2 to 2.5 mm<sup>2</sup> / 24 to 14 AWG (solid, stranded, and bootlace ferrules)</li></ul>



## Shelly Pro 3EM-3CT63 datasheet

Conductor stripped length:	6 to 7 mm / 0.24 to 0.28 in
Mounting:	<ul style="list-style-type: none"><li>• Shelly Pro 3EM-3CT63: DIN rail</li><li>• Shelly 3CT63: Freestanding on phase wires</li></ul>
Conductor aperture Shelly 3CT63:	Ø9 mm / Ø0.35 in
Shell material:	Plastic
Shell color:	White
<b>Environmental</b>	
Ambient working temperature:	-20°C to 40°C / -5°F to 105°F
Humidity:	30% to 70% RH
Max. altitude:	2000 m / 6562 ft
<b>Electrical</b>	
Power supply:	100-260 V~ 50/60 Hz
Power consumption:	< 3 W
External protection:	Tripping characteristic B or C, 16A max. rated current, min. 6 kA interrupting rating, energy limiting class 3
Shelly 3CT63 electrical strength:	1000 V~, 60 sec
<b>Sensors, meters</b>	
Internal-temperature sensor:	Yes
Voltmeter (AC):	100 - 260 V
Voltmeter accuracy:	±1 %
Ammeter (AC):	0 - 63 A
Ammeter accuracy:	±1 % (2 - 63 A), ±2 % (1 - 2 A), ±5 % (0 - 1 A)
Compatible current transformers:	3CT63
Power and energy meters:	<ul style="list-style-type: none"><li>• Active and apparent power</li><li>• Active and apparent energy</li><li>• Power factor</li><li>• Fundamental active and fundamental reactive energy</li></ul>



## Shelly Pro 3EM-3CT63 datasheet

Channel-to-channel calibration minimum load:	500 W per channel
No load threshold:	30 VA per channel
Measurement data storage:	At least 60 days of 1 min data resolution
Data export:	<ul style="list-style-type: none"><li>• CSV for PQ recorded values</li><li>• JSON format export through RPC</li></ul>
<b>Radio</b>	
<b>Wi-Fi</b>	
Protocol:	802.11 b/g/n
RF band:	2400 - 2495 MHz
Max. RF power:	< 20 dBm
Range:	Up to 30 m / 100 ft indoors and 50 m / 160 ft outdoors (Depends on local conditions)
<b>Bluetooth</b>	
Protocol:	4.2
RF band:	2400 - 2483.5 MHz
Max. RF power:	< 4 dBm
Range:	Up to 10 m / 33 ft indoors and 30 m / 100 ft outdoors (Depends on local conditions)
<b>Microcontroller unit</b>	
CPU:	ESP32-D0WDQ6
Flash:	16 MB
<b>Firmware capabilities</b>	
Webhooks (URL actions):	20 with 5 URLs per hook
Scripting:	Yes
MQTT:	Yes
Scripting:	Yes
Encryption:	Yes

## Shelly Pro 3EM-3CT63 datasheet

### Basic wiring diagrams

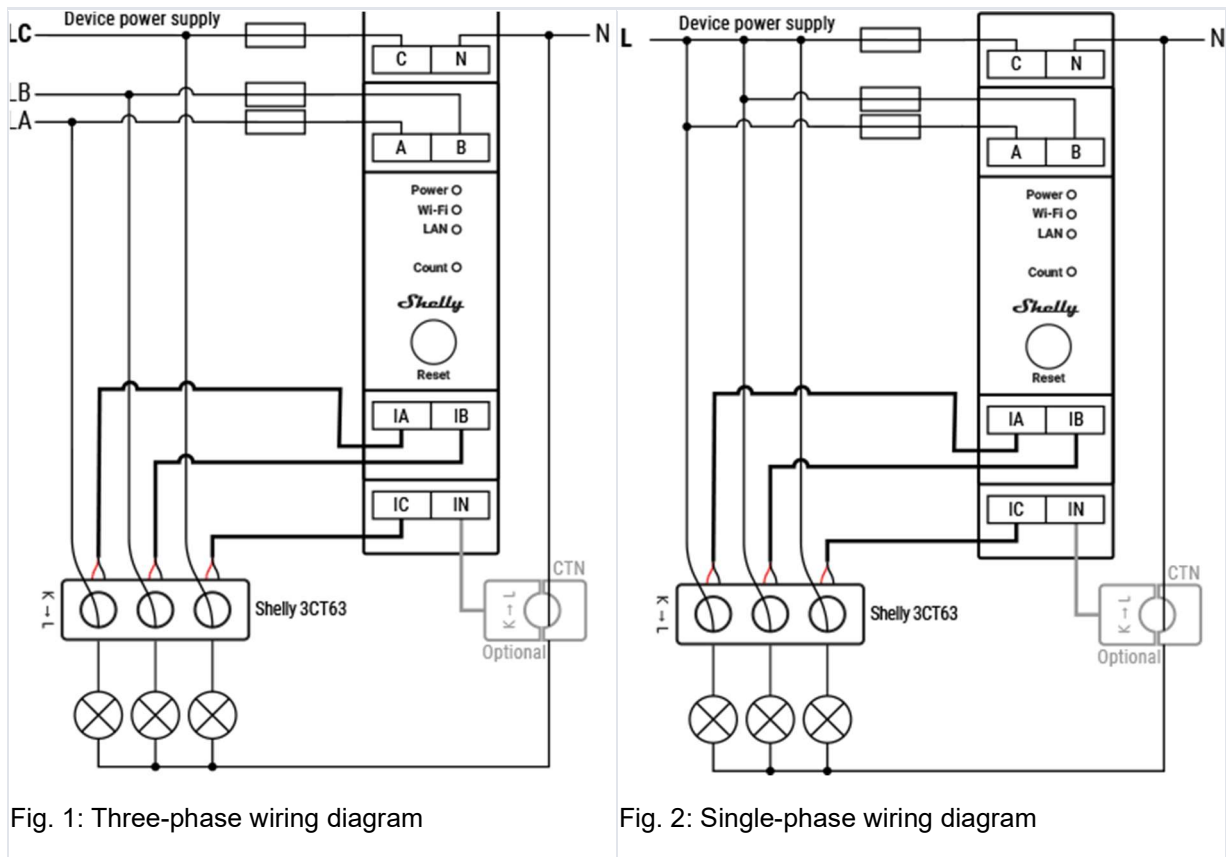

Fig. 1: Three-phase wiring diagram

Fig. 2: Single-phase wiring diagram

### Legend

Terminals		Wires	
<b>A:</b>	Phase A terminal	<b>LA:</b>	Phase A live (110-240 V~) wire
<b>B:</b>	Phase B terminal	<b>LB:</b>	Phase B live (110-240 V~) wire
<b>C:</b>	Phase C terminal	<b>LC:</b>	Phase C live (110-240 V~) wire
<b>N:</b>	Neutral terminal	<b>N:</b>	Neutral wire
<b>IA:</b>	Phase A current transformer input		
<b>IB:</b>	Phase B current transformer input		
<b>IC:</b>	Phase C current transformer input		
<b>IN:</b>	Neutral current transformer input		
<b>Current transformers</b>			
<b>3CT63:</b>	3-phase current transformer/63A		
<b>CTN:</b>	Neutral current transformer (optional, not included)		



## Shelly Pro 3EM-3CT63 datasheet

K->L:	Direction of the primary current flow		
-------	---------------------------------------	--	--



# Shelly Pro 3EM-3CT63 datasheet

## Installation

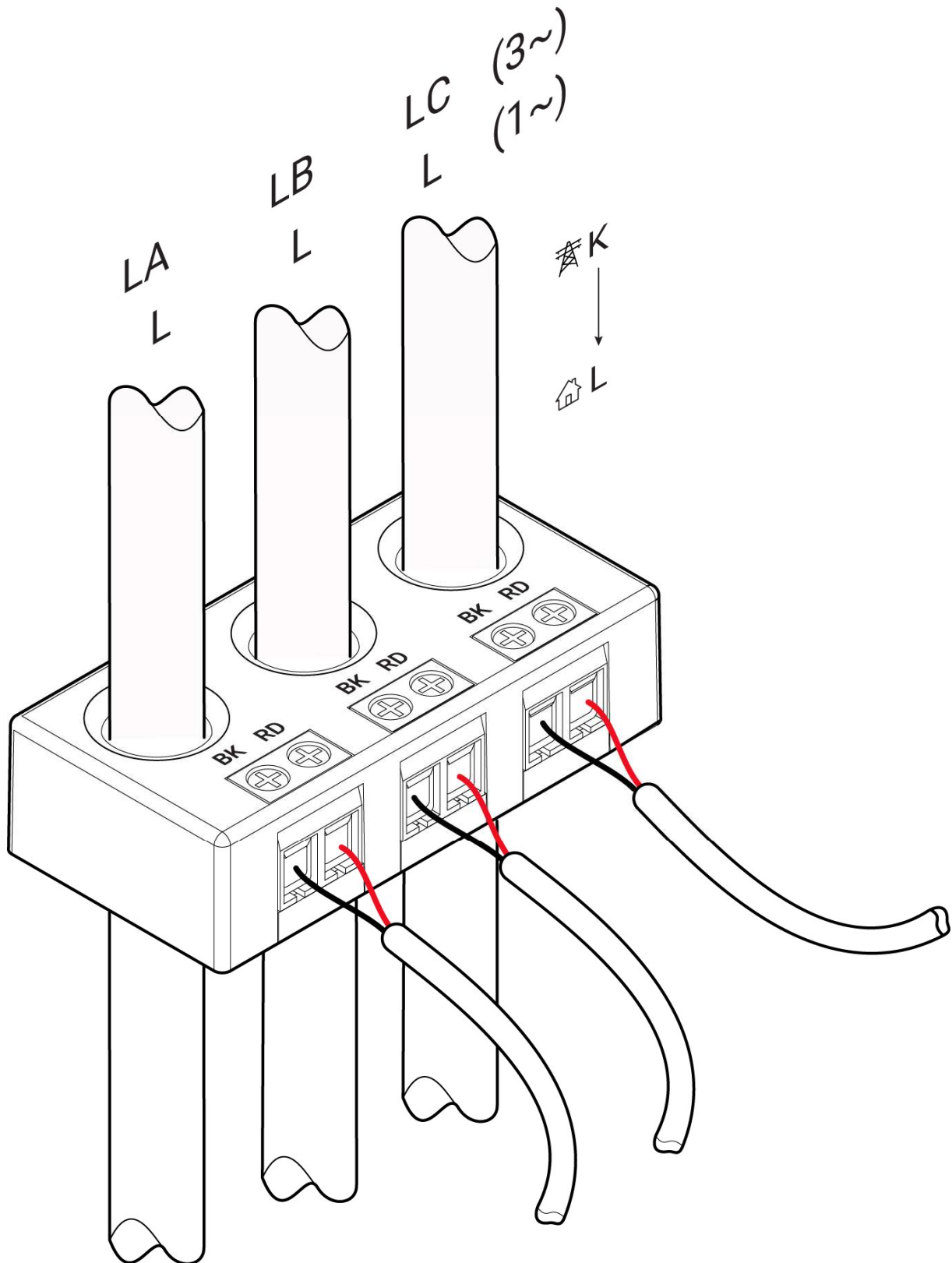



# Shelly Pro 3EM-3CT63 datasheet

## Legend

LA, LB, LC:	Three-phase setup (3~)
L:	Single-phase setup (1~)
RD:	Red wire
BK:	Black wire
K ->L:	Direction of the primary current flow

## Shelly Smart Control

- [Adding the device to the Shelly Smart Control](#)

## Troubleshooting

- **Check the correct installation of the CT:**
  - If negative readings on a measured circuit are read and are not expected, check the correct installation of the CT (K->L).
- **Ensure that the device is properly powered:**
  - Check power cables, outlets, and any power indicators on the device.
- **Inspect Connections:**
  - Verify that all connections, including cables and wiring, are secure and properly seated. Loose connections can lead to functionality issues.
- **Review Device Settings:**
  - If applicable, check and review the device settings. Ensure that configurations are correct and match your intended use.
- **Update Firmware/Software:**
  - Check if there are any available firmware or software updates for the device. Keeping the device up-to-date can resolve known issues and improve performance.
- **Restart or Reboot:**
  - Sometimes, a simple restart can resolve temporary glitches. Turn off the device, wait a few seconds, and then power it back on.
- **Check Network Connection:**
  - If the device is connected to a network, ensure that the network settings are correct. Test the network connection and consider restarting routers or switches if needed.
- **Inspect Physical Components:**
  - Physically inspect the device for any signs of damage, overheating, or unusual behavior.
- **Check Compatibility:**
  - Ensure that the device is compatible with other components in your system, including hardware and software. Incompatibility issues can lead to malfunctions.
- **Monitor Environmental Factors:**
  - Consider environmental factors such as temperature and humidity.
- **Inspect Power Supply Quality:**
  - Poor power quality, including voltage spikes or fluctuations, can affect device performance. Consider using a surge protector or voltage regulator if needed.



# Shelly Pro 3EM-3CT63 datasheet

\*These are general troubleshooting steps, and the specific steps may vary based on the type of device or issue you are facing. If the issue persists and you are unable to resolve it, consider reaching out to our [technical customer support](#).

## Components and APIs

- [This device](#)
- [All Shelly devices and services](#)

## Compliance

- [Shelly Pro 3EM 3CT63 multilingual EU declaration of conformity 2025-07-30.pdf](#)
- [Shelly Pro 3EM-3CT63 AU NZ Certificate for Suitability.pdf](#)
- [Shelly Pro 3EM-3CT63 UK PSTI ACT Statement of compliance.pdf](#)

## Printed user guide

[Shelly Pro 3EM-3CT63 multilingual printed user and safety guide.pdf](#)